



HOLZ-HER EPICON 7135 - SPACE SAVER

COMPACT, POWERFUL AND WELL
THOUGHT TROUGH

EPICON 7135 SPACE SAVER



The 360° access concept allows free access from all sides - ideal for maintenance, care and material handling.

EPICON 7135 SPACE SAVER



- 1 FULL BUMPER TECHNOLOGY
- 2 ENCLOSED VACUUM PUMP
- 3 TOOL CHANGER VARIANTS

- 4 PERMANENTLY MOUNTED ELECTRICAL CABINET
- 5 FLEXIBLE TABLE CONCEPTS
- 6 POWERFUL 5-AXIS SPINDLE

MACHINING DIMENSIONS

Maximum working range

With a maximum processing height of 300 millimetres from the top edge of the vacuum cup (125 mm), the 7135 Space Saver offers enough space for your projects.

Row drilling and grooving saw cover the entire working area between the stops.



X	Machining dimension	BETWEEN THE STOPS
315	Max. 3620 mm	3150 mm
405	Max. 4520 mm	4050 mm
Y	Max. 1500 mm	1280 mm
Z	300 mm	-

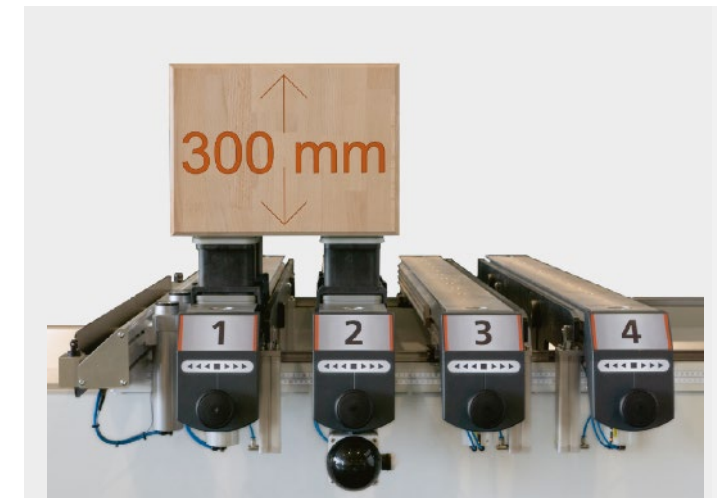
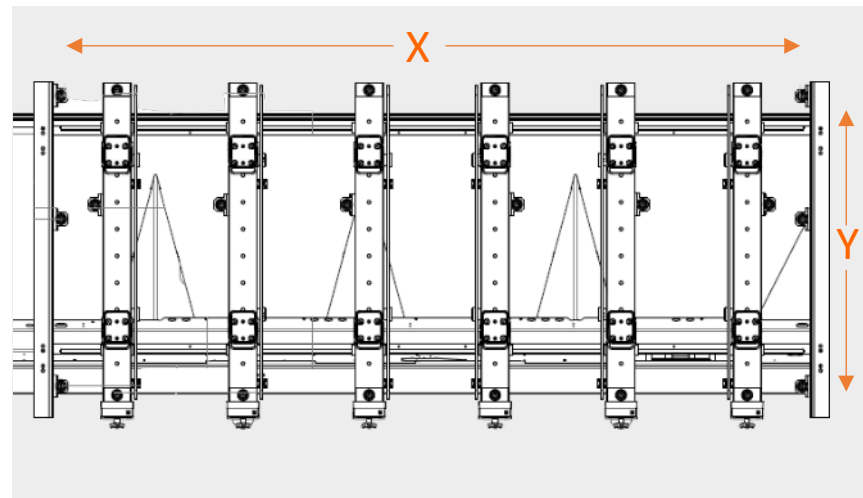

FLEXIBLE INSTALLATION SCENARIOS

Compact, powerful and well thought out

Thanks to the innovative bumper technology, the machine offers maximum safety without the need for complex protective enclosures such as safety mats or safety fences.

The result is maximum flexibility in positioning, even directly against walls or in corners. The 360° access concept allows free access from all sides and is therefore ideal for maintenance, care and material handling. The machine is operated from the front.

To further simplify transportation, the control cabinet and the vacuum pump are already permanently mounted on the machine frame.

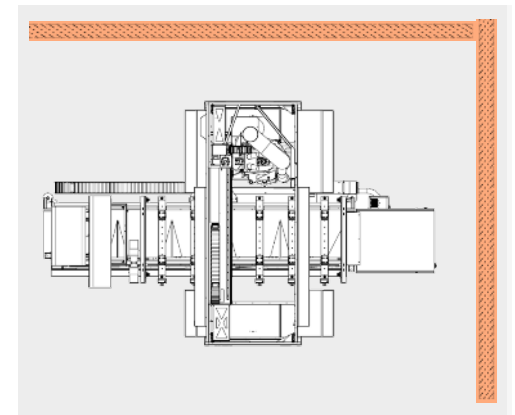
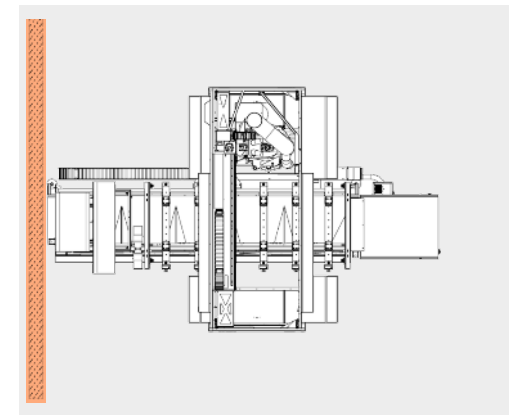
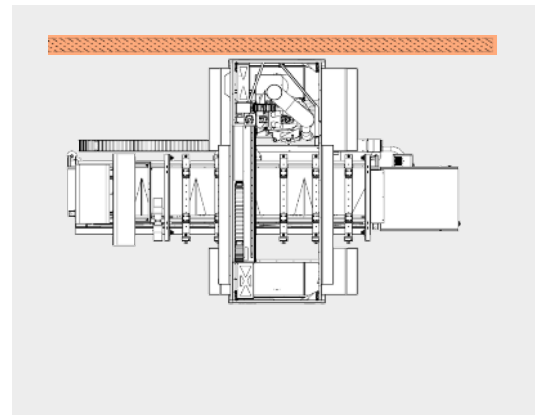
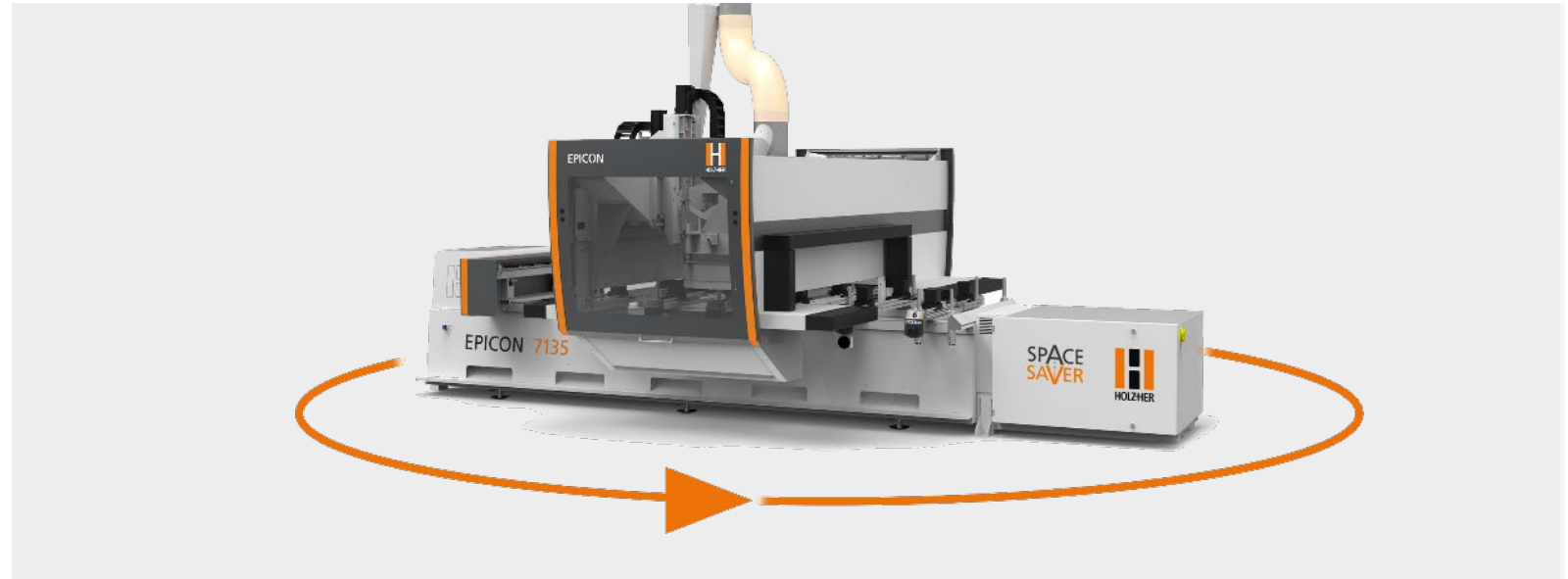

EASY START

Short distances and high efficiency

Enables convenient operation and short distances due to additional start button on the machine hood at the front. This is an indispensable option, especially for pendulum machining and in combination with the 7135 Space Saver!

OPERATING FUNCTIONS:

- Start / stop the processing program
- Reset button

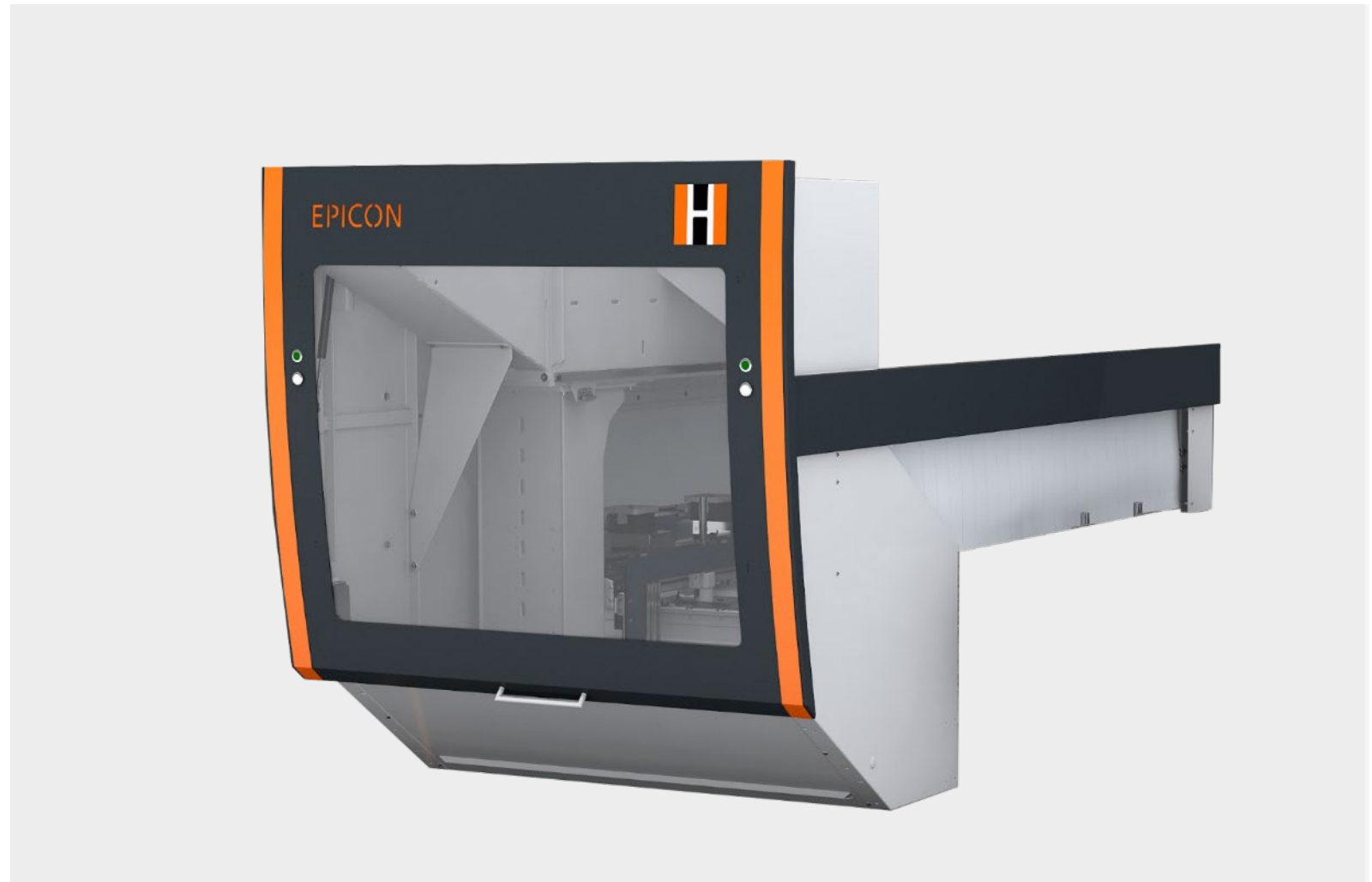

TOOL CHANGER

Performance-oriented solutions

The EPICON 7135 Space Saver is already equipped with an 18-position disk changer as standard. In addition to shank and profile tools, this can also accommodate saw blades with a diameter of up to 350 mm!

A linear changer, which is permanently mounted on the left-hand side of the machine, is available as an option for **even more tool positions**. The linear changer can be equipped with up to 16 additional tools.

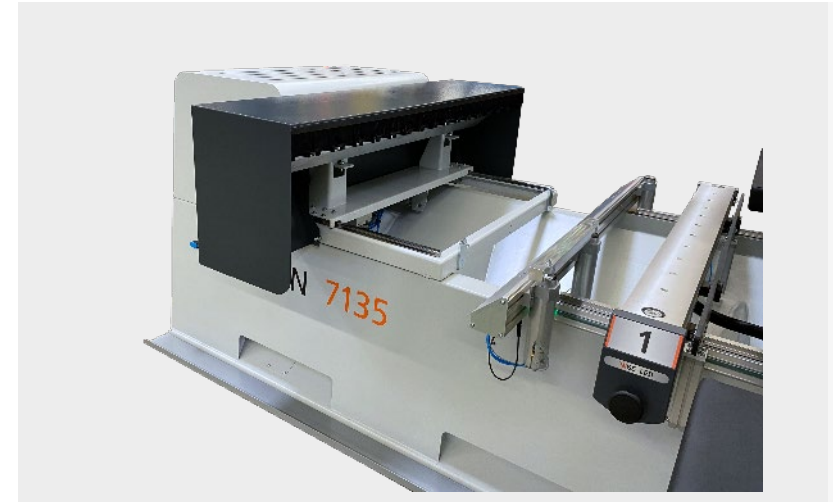

SIDE ACCESS DOOR

Easy access

An access door is located on the side of the machine to allow easy access to the traveling tool changer, even when the machine is positioned against the wall.

This enables the tools to be loaded quickly and safely by hand.

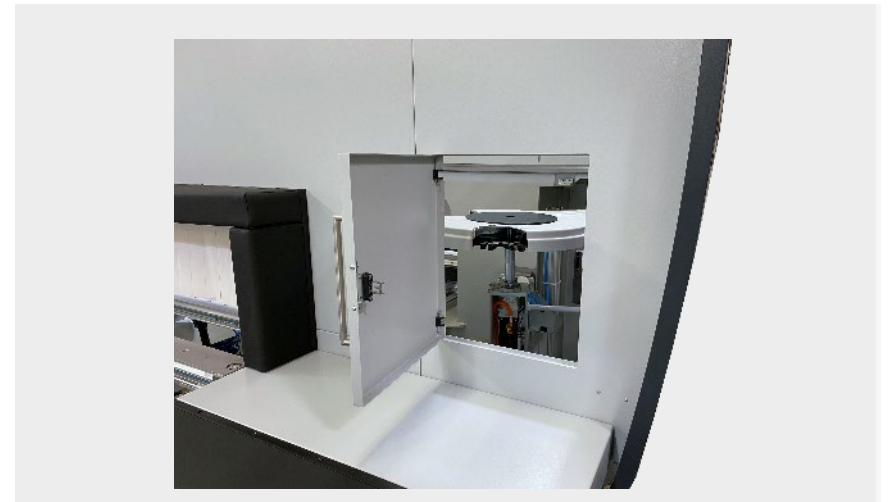
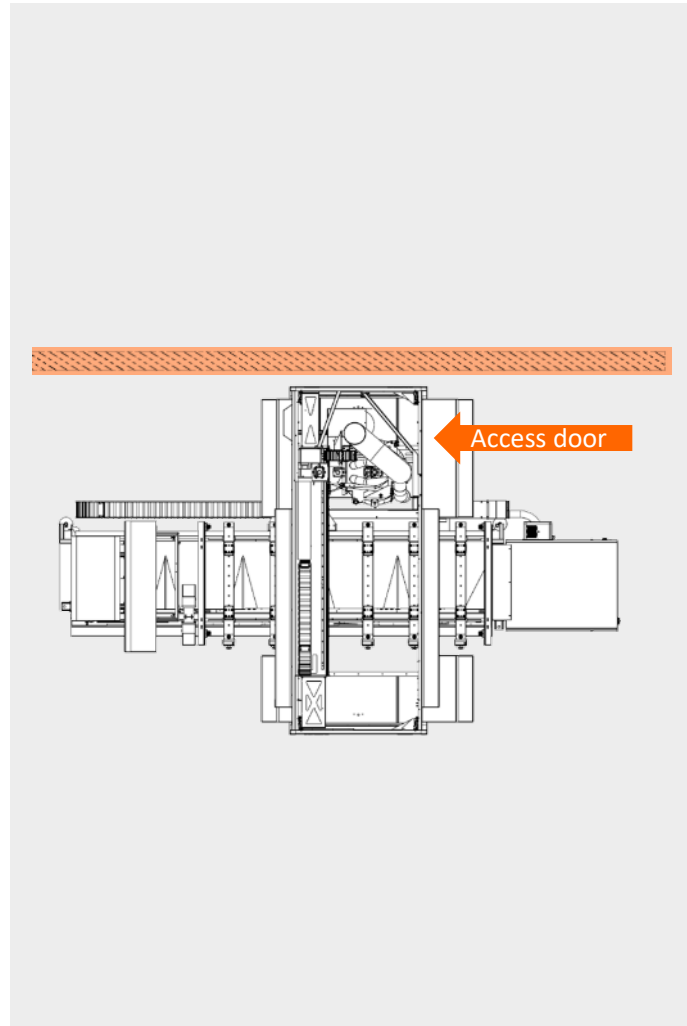

VACUUM PUMP

Safely stowed away

To further reduce the installation dimensions of the machine, the BECKER rotary vane pump with 100 m³/h or 140 m³/h (dry-running) was mounted on the left-hand side of the machine frame and enclosed.

The pump is already fully assembled and connected during transportation.

Additional vacuum pumps and other versions must be placed individually next to the machine.

